

ACTUAL FLANGE WIDTH SETTING (IN)	7.280	8.700	14.200	19.700
MINIMUM HEADROOM DIMENSION "A" (IN)	63.78	63.78	63.78	63.78

TECHNICAL DATA	
HOIST PLATFORM	GN WIRE ROPE HOIST
HOIST MODEL NUMBER	YKE-S25-066S412-2
RATED LIFT CAPACITY	25 U.S. TON
ACTUAL LIFT DISTANCE	66 FT (20.1 M)
MAXIMUM LIFTING SPEED	12 FT/MIN (3.7 M/MIN)
REEVING STYLE	4-PART SINGLE-REEVED
HOIST CONTROL TYPE	TWO-SPEED
HOIST SUSPENSION TYPE	UNDERHUNG MOTORIZED TROLLEY
TROLLEY TRAVERSE SPEED	80 FT/MIN (24.38 M/MIN)
TROLLEY CONTROL TYPE	TWO-SPEED
TROLLEY BUMPER	INCLUDED
HOIST DUTY CLASSIFICATION	H4
OPERATING VOLTAGE	460V/3PH/60Hz
CONTROL VOLTAGE	120VAC
HOIST MOTOR (MAIN) HP	26.8
TROLLEY MOTOR HP	2 x 0.9
TROLLEY MOTOR QTY	2
BASE WEIGHT OF HOIST (LBS)	7028

FLANGE ADJUSTMENT RANGES
7.280" - 8.700"
8.701" - 14.200"
14.201" - 19.700"

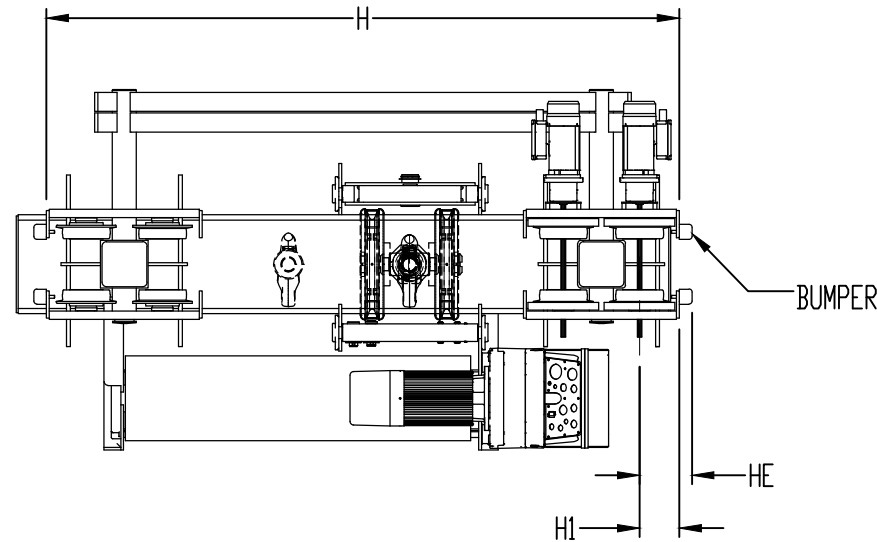

DIMENSIONAL DATA	
B	64.98 INCH
C	44.59 INCH
D*	30.69 INCH
E*	28.86 INCH
Q	27.84 INCH
W*	26.91 INCH
WTD	7.87 INCH
WB	91.42 INCH
H	104.57 INCH
H1	6.57 INCH
HE	8.66 INCH
XB	3.94 INCH
AP	38.02 INCH
AQ	15.28 INCH

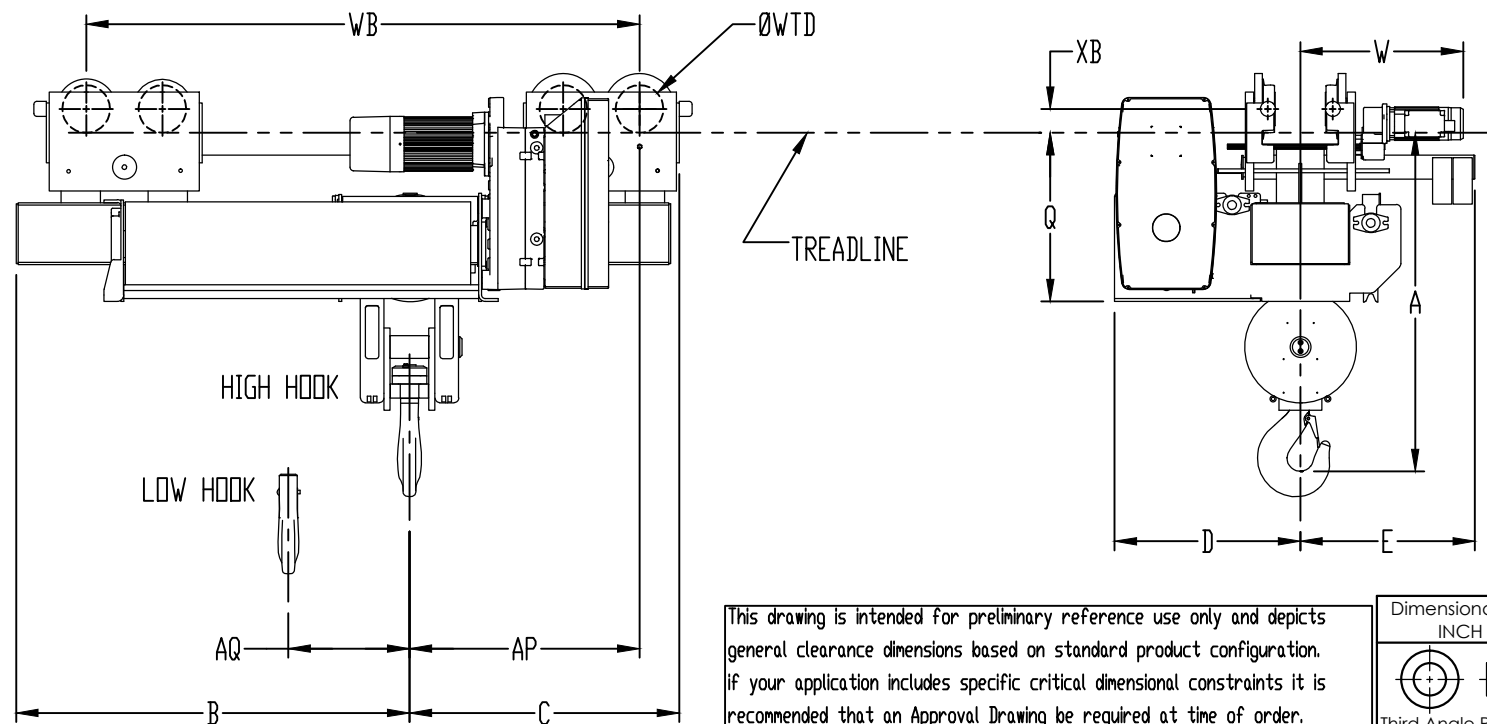

This drawing is intended for preliminary reference use only and depicts general clearance dimensions based on standard product configuration. If your application includes specific critical dimensional constraints it is recommended that an Approval Drawing be required at time of order.

Dimensional Units  
INCH

Third Angle Projection

Modeled:	11/23/2018	SRCCE
Drawn:	11/23/2018	SRCCE
Approved:		
Design Authority:		
Original project:		
Original Scale:	1:30	

**2- SPEED**

Description:  
**CLEARANCE DIAGRAM**  
25 TON 66 FT LIFT S4 REEVING 12 FT/MIN

Format	Number:	Sheet
<b>B</b>	<b>YKE-S25-066S412-2</b>	<b>1</b>

NOTE:

\* DIMENSIONS D, E, AND W ARE SHOWN FOR A BEAM FLANGE WIDTH 8.00 INCHES. THESE DIMENSIONS ARE MEASURED FROM CAD MODELS AND CONSIDERED AS APPROXIMATE VALUES.

ECN	Rev.	Description of change	Date	By
-	-	-	-	-
-	-	-	-	-
-	-	-	-	-

ACTUAL FLANGE WIDTH SETTING (IN)	7.280	8.700	14.200	19.700
MINIMUM HEADROOM DIMENSION "A" (IN)	63.78	63.78	63.78	63.78

TECHNICAL DATA	
HOIST PLATFORM	GN WIRE ROPE HOIST
HOIST MODEL NUMBER	YKE-S25-066S412-V
RATED LIFT CAPACITY	25 U.S. TON
ACTUAL LIFT DISTANCE	66 FT (20.1 M)
MAXIMUM LIFTING SPEED	12 FT/MIN (3.7 M/MIN)
REEVING STYLE	4-PART SINGLE-REEVED
HOIST CONTROL TYPE	VARIABLE SPEED
HOIST SUSPENSION TYPE	UNDERHUNG MOTORIZED TROLLEY
TROLLEY TRAVERSE SPEED	80 FT/MIN (24.38 M/MIN)
TROLLEY CONTROL TYPE	TWO-SPEED
TROLLEY BUMPERS	INCLUDED
HOIST DUTY CLASSIFICATION	H4
OPERATING VOLTAGE	460V/3PH/60Hz
CONTROL VOLTAGE	120VAC
HOIST MOTOR (MAIN) HP	26.8
TROLLEY MOTOR HP	2 x 0.9
TROLLEY MOTOR QTY	2
BASE WEIGHT OF HOIST (LBS)	7028

FLANGE ADJUSTMENT RANGES
7.280' - 8.700'
8.701' - 14.200'
14.201' - 19.700'

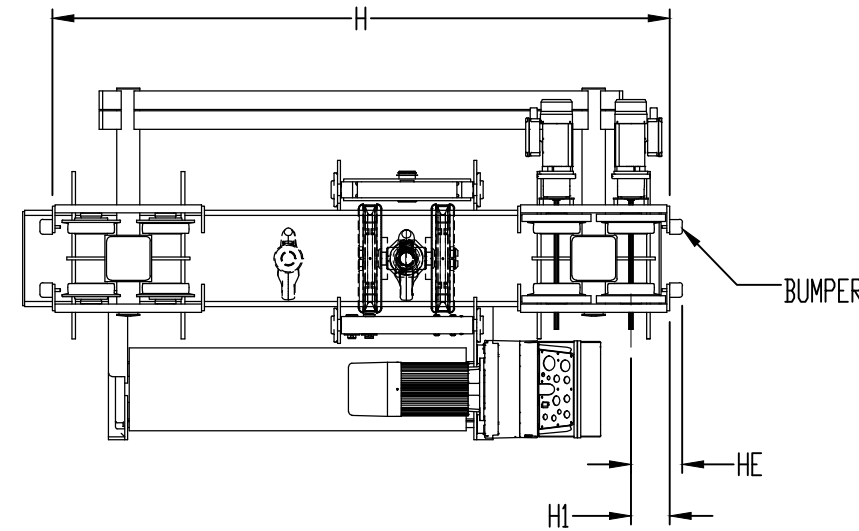

DIMENSIONAL DATA	
B	64.98 INCH
C	44.59 INCH
D*	30.69 INCH
E*	28.39 INCH
E1*	38.83 INCH
Q	27.84 INCH
W*	26.91 INCH
WTD	7.87 INCH
WB	91.42 INCH
H	104.57 INCH
H1	6.57 INCH
HE	8.66 INCH
XB	3.94 INCH
AP	38.02 INCH
AQ	15.28 INCH

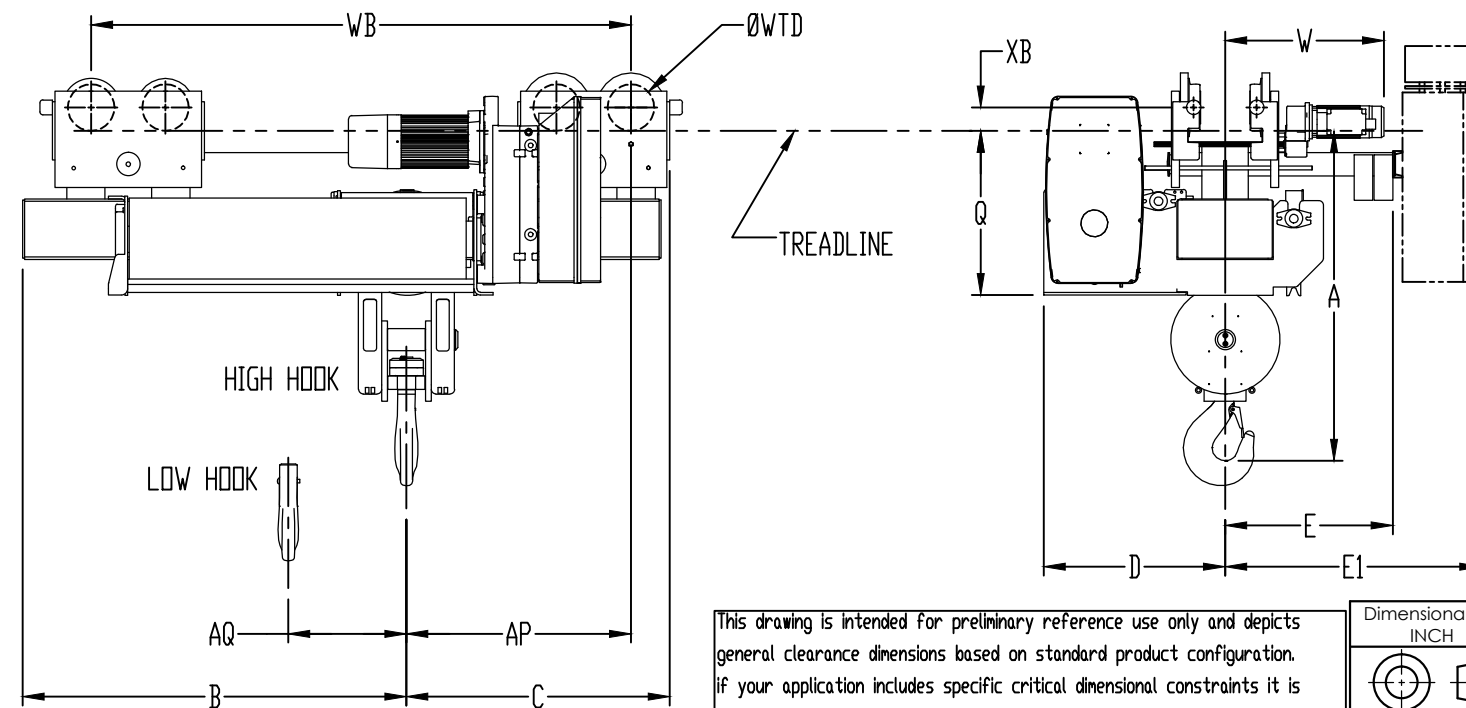

This drawing is intended for preliminary reference use only and depicts general clearance dimensions based on standard product configuration. If your application includes specific critical dimensional constraints it is recommended that an Approval Drawing be required at time of order.

Dimensional Units  
INCH  
Third Angle Projection

Modeled:	11/23/2018	SRCCE
Drawn:	11/23/2018	SRCCE
Approved:		
Design Authority:		
Original project:		
Original Scale:	1:30	

**VARIABLE SPEED**

Description:  
**CLEARANCE DIAGRAM**  
25 TON 66 FT LIFT S4 REEVING 12 FT/MIN

Format	Number:	Sheet
<b>B</b>	<b>YKE-S25-066S412-V</b>	<b>2</b>

NOTE:

\* DIMENSIONS D, E, E1 AND W ARE SHOWN FOR A BEAM FLANGE WIDTH 8.00 INCHES. THESE DIMENSIONS ARE MEASURED FROM CAD MODELS AND CONSIDERED AS APPROXIMATE VALUES.

ECN	Rev.	Description of change	Date	By
-	-	-	-	-
-	-	-	-	-
-	-	-	-	-